



日菱實業有限公司
NITSU INDUSTRIAL LTD.

深圳市神田機械設備有限公司
SHENZHEN SHENTIAN MACHINERY EQUIPMENT CO., LTD.

真空吸塑成型機

High Speed Automatic Vacuum Forming Machine

NS 28, NS 38, NS 38L



技術數據 Technical Data

基本型號 Basic version		NS 28	NS 38	NS 38L
成型面積 Forming area	Max.	1120×710mm	1120×760mm	1120×760mm
	Min.	300×510mm	200×460mm	200×460mm
材料寬度 Material width	Max.	760mm	810mm	810mm
材料寬度 Material width	Min.	560mm	510mm	510mm
材料厚度 Material thickness	Max.	1.5mm	1.5mm	1.5mm
材料厚度 Material thickness	Min.	0.15mm	0.15mm	0.15mm
送料方式 Material transport		變頻電機 Freq. Inverter	交流伺服電機 AC Servo motor	交流伺服電機 AC Servo motor
送料精度 Accuracy of material transport		±2mm	±0.3mm	±0.3mm
成型高度 Depth of draw	Max.	200mm	200mm	200mm
上模台行程 Stroke of upper table	Max.	450mm	450mm	450mm
下模台行程 Stroke of lower table	Max.	370mm	370mm	370mm
模台驅動 Table drives		氣動 Pneumatic	氣動 Pneumatic	氣動 Pneumatic
真空泵浦 Vacuum pump		100cum/hr	100cum/hr	100cum/hr
上爐 Upper heating		54×650watt	63×650watt	70×650watt
下爐 lower heating		無	40×650watt	45×650watt

伺服電機驅動真空吸塑成型機

Servo Drives Automatic Vacuum Forming Machine

NSS 58, NSS 58L



技術數據 Technical Data

基本型號 Basic version		NSS 58	NSS 58L
成型面積 Forming area	Max.	1120×760mm	1120×760mm
	Min.	200×460mm	200×460mm
材料寬度 Material width	Max.	810mm	810mm
材料寬度 Material width	Min.	510mm	510mm
材料厚度 Material thickness	Max.	1.5mm	1.5mm
材料厚度 Material thickness	Min.	0.15mm	0.15mm
送料方式 Material transport		交流伺服電機 AC Servo motor	交流伺服電機 AC Servo motor
送料精度 Accuracy of material transport		±0.3mm	±0.3mm
成型高度 Depth of draw	Max.	200mm	200mm
上模台行程 Stroke of upper table	Max.	450mm	450mm
下模台行程 Stroke of lower table	Max.	400mm	400mm
模台驅動 Table drives		交流伺服電機 AC Servo motor	交流伺服電機 AC Servo motor
真空泵浦 Vacuum pump		160cum/hr	160cum/hr
上爐 Upper heating		63×650watt	70×650watt
下爐 lower heating		40×650watt	45×650watt

全自動壓空成型機

Automatic Pressure forming Machine



NSPF 68, NSPF 78, NSPF 98

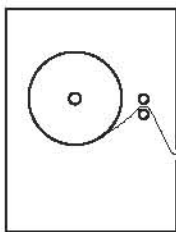

上料架
material
roll stand

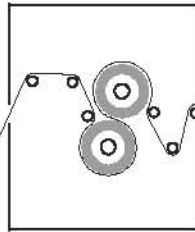

PP預熱爐
roll pre-heater for
PP processing

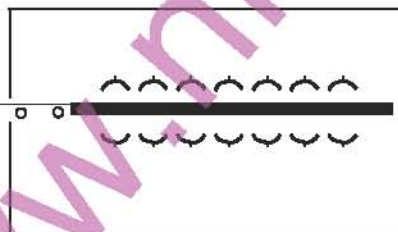

輻射式加熱系統
radiation heater in
forming machine

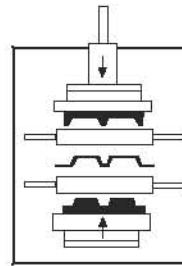

成型沖剪
separate forming and punching with
integrated steel rule punch press

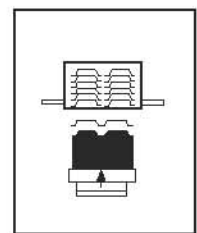
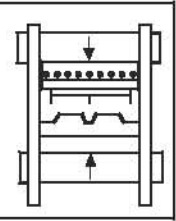

堆疊整理
stacking station

提供高靈活性的模塊化生產設備，成型，小孔沖剪，板刀片模沖切及堆疊整理裝置等配搭。

High flexibility is provided by the modular machine design for forming/punching operations as well as for separation forming/punching and stacking.

NSPF 68

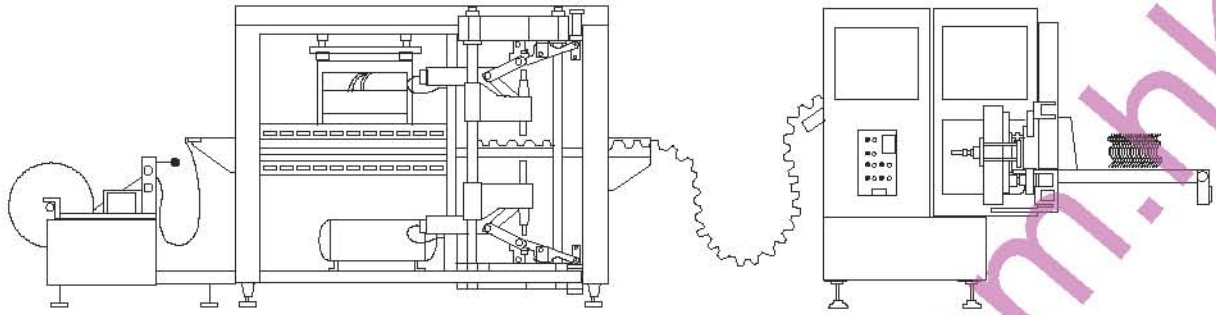

全自動壓空成型機帶分體式沖剪生產線
Automatic pressure forming machine with Punch and die press

NSPF 78

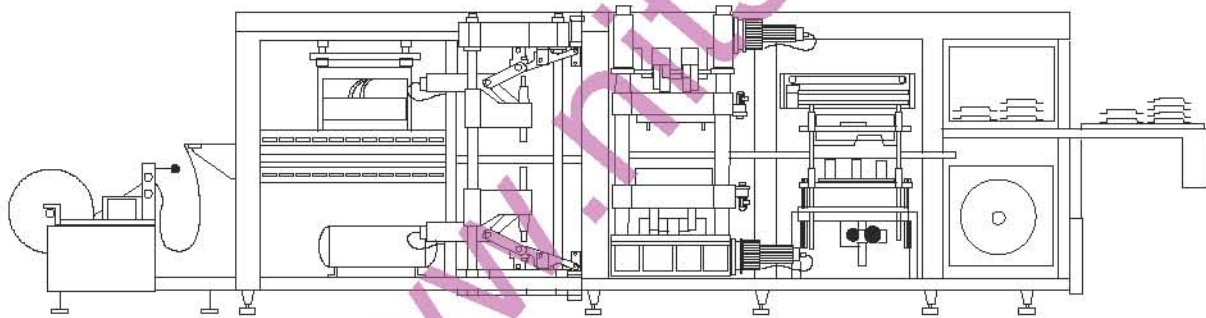

全自動壓空成型機帶板鋼刀沖剪生產線
Automatic pressure forming machine with steel rule punch press

NSPF 98

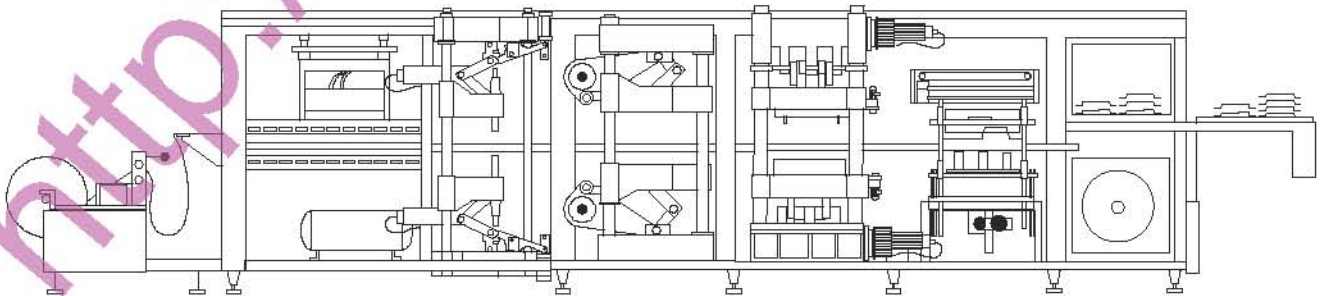

全自動壓空成型機帶小孔及板鋼刀沖剪生產線
Automatic pressure forming machine with hole punch press and steel rule punch press

全自動壓空成型機

Automatic Pressure forming Machine

技術數據 Technical Data

基本型號 Basic version		NSPF 68	NSPF 78	NSPF 98
成型面積 Forming area	Max.	410×560mm	560×760mm	560×760mm
成型及沖切可使用面積 Forming area in forming /punching area	Max.	400×550mm	547×747mm	547×747mm
模具寬度 Tool width	Max.	585mm	784mm	784mm
模具長度 Tool length	Max.	440mm	590mm	590mm
材料寬度 Material width	Max.	610mm	810mm	810mm
材料寬度 Material width	Min.	200mm	250mm	250mm
材料厚度 Material thickness	Max.	2.5mm	2.5mm	2.5mm
材料厚度 Material thickness	Min.	0.18mm	0.18mm	0.18mm
送料精度 Accuracy of material transport		±0.3mm	±0.3mm	±0.3mm
送料長度 Feed length	Max.	425mm	578mm	578mm
	Min.	150mm	200mm	200mm
成型高度, 正模 Depth of draw, positive	Max.	120mm	120mm	120mm
成型高度, 反模 Depth of draw, negative	Max.	120mm	120mm	120mm
真空泵浦 Capacity vacuum pump		100cum/hr	160cum/hr	160cum/hr
合模力 Mould closing force	Max.	150kN	300kN	300kN
小孔沖剪力 Hole punching force	Max.			200kN
板刀沖剪力 Steel rule punching force	Max.	300kN	500kN	500kN
成型空氣壓力 Forming pressure	Max.	5 bar	6 bar	6 bar
生產速度 Number of cycle, forming and punching	Max.	30/min	30/min	30/min
上/下加熱系統 Upper/lower heating	Max.	45.5kW	91.0kW	91.0kW
送料, 成型上下工作台, 小孔沖剪, 板刀的驅動形式 Material transport, upper/lower forming tables, hole punching and steel Rule punching drives		交流伺服電機 AC Servo motor	交流伺服電機 AC Servo motor	交流伺服電機 AC Servo motor

吸塑首辦機

Blister Forming Machine



技術數據 Technical Data

型號 MODEL	S-8
成型尺寸 Forming	510×570mm
真空泵 Vaccuum Pump	10m3/hr
發熱管 Heater	Ceramic 6400W
機械尺寸 Dimension	L1700×W900H×1350mm

自動三邊折邊機

Three Edge Edging Machine



技術數據 Technical Data

型號 MODEL	BCM-2		
裁斷尺寸 Cutting Size (inch)	30	46	50
裁斷壓力 Cutting Pressure	10Ton		
最小封閉高度 Minimum Enclosed Die Space	95mm		
最大封閉高度 Maximum Enclosed Die Space	195mm		
工作台尺寸 Size of Working Table (mm)	780×410	1160×410	1280×410
電源 Power Supply	AC 3P/380V/50Hz		

機械式裁斷機 Mechanical Cutting Machine



技術數據 Technical Data

型號 MODEL	S-3	S-6
折邊尺寸 Edging Size	W350×L600mm	W400×L950mm
折邊高度 Edging Height	120mm	140mm
生產速度 Production Speed	600~800pc/hr	400~600pc/hr
電源 Power Supply	600~800pc/hr	400~600pc/hr
機械尺寸 Dimension	L900×W720H×1650mm	L1220×W760H×1650mm

四柱油壓裁斷機 Hydraulic cutting Machine



技術數據 Technical Data

型號 MODEL	BCM-30T
最大壓力 Maximum Pressure	30Ton
行程調節範圍 Cutting Stroke	40-150mm
上壓板面積 Upside Board Area	1625×508mm
工作臺面積 Work Desk Area	1625×610mm
馬達功率 Motor Power	3KW
機械尺寸 Dimension	2030×810×1500mm
重量 Net Weight	1600KG

產品系列及規格如有變動, 恕不另行通知/We reserve the right to make change to the above specification without notification.

恒通工業冷水機廠
HANG TONG INDUSTRIAL CHILLER FTY.

日菱實業有限公司
NITSU INDUSTRIAL LTD.

深圳市神田機械設備有限公司
SHENZHEN SHENTIAN MACHINERY EQUIPMENT CO., LTD.

香港公司 Hong Kong Company:
香港新界葵涌葵福道晉昇工業大廈10樓1010室
Rm 1010, 10/F., Chun Sing Factory Building,
Kwai Fuk Road, Kwai Chung, N.T., Hong Kong.
電話Tel: 852-2408 2195
傳真Fax: 852-2406 2854
電郵E-mail: hongtong@netvigator.com
網頁Website: www.nitsu.com.hk

上海辦事處 Shanghai Office:
上海市松江區 Song-Jiang District, Shanghai, China.
電話 Tel: 021-5785 3309 傳真Fax: 021-5785 3210

深圳廠址 Shenzhen Factory:
深圳市松崗鎮東方大道大田洋
紅星龍門工業區(松崗中學斜對面)
Datianyang Industrial Zone, Hongxing
Longmen Village, Song Gang Town,
Shenzhen City, Guangdong Prov., China.
電話 Tel: 0755-2753 3331
傳真 Fax: 0755-2753 3329